

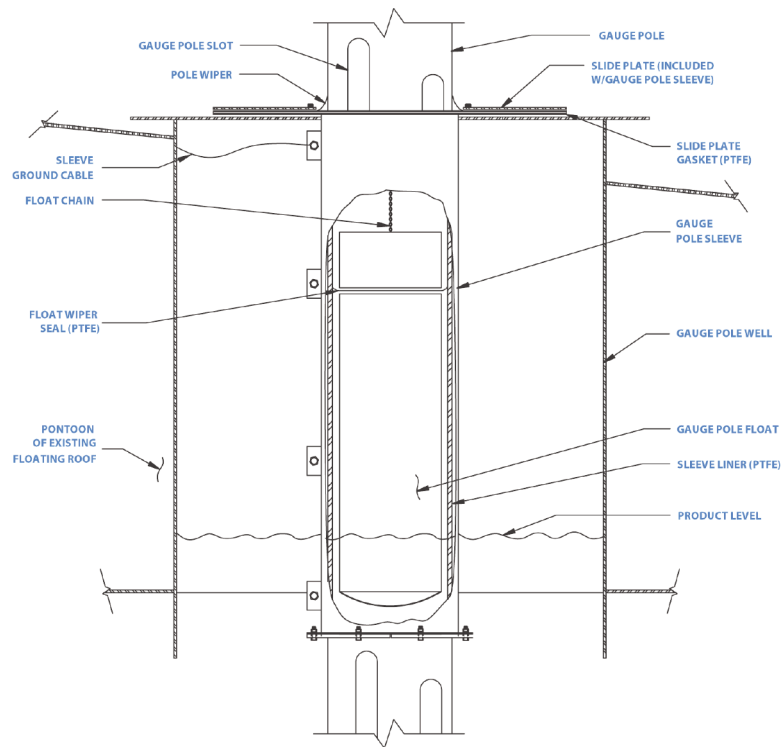

Gauge Pole Float and Sleeve



Various regulatory agencies are requiring that slotted gauge/guide poles be equipped with an emissions control system. The HMT Gauge Pole Float and Sleeve has been designed to significantly reduce hydrocarbon emissions from slotted gauge/guide poles located on either external or internal floating roof storage tanks.

The HMT Gauge Pole Float and Sleeve features a “low-profile,” stainless steel sleeve containing a 25-mil Petroflex™ PTFE (Teflon®) liner and pole wiper. This liner provides excellent chemical and abrasion resistance and effectively closes the slots in the gauge pole. The sleeve is equipped with a stainless steel slide plate containing a 10-mil reinforced Teflon gasket.

The sleeve completely seals off all the slots of the gauge pole within the gauge well, eliminating vapor emissions through the gauge pipe.

The stainless steel float contains a 10-mil Teflon wiper and is designed to operate in specific gravities ranging from 0.60 to 1.00. It effectively “plugs” the gauge pole, preventing vapors from escaping to the atmosphere.

Both the float and sleeve are designed to be installed with the storage tank remaining in service. Additionally, the HMT Gauge Pole Float Basin should be considered as part of this complete installation for additional emission control.

This new emission control system is another example product of HMT’s “Innovative Solutions” philosophy and commitment to providing quality products to the petroleum industry.

Contact your local HMT Representative to discuss the full suite of products and services that will satisfy all your AST needs.

The Gauge Pole Float and Sleeve Advanced Design Features Include:

- Resistant to all stored products—stainless steel construction and components.
- PTFE (Teflon®) liners and wiper materials compatible with all stored products, abrasion resistant.
- Low profile—Sleeve length sized to fit type of well and floating roof (18" to 36" in overall lengths, overall length of float is 18")
- Designed for a long service life.
- Constructed with lightweight stainless steel.
- Maintenance free.
- Easily installed without removing the tank from service.



HMT Inc.
23832 Tomball Parkway
Tomball, Texas 77375
Ph: +1.281.681.7000
Fax: +1.281.351.8589

Locations worldwide to service
all your AST needs.

Visit us at www.hmttank.com

Petroflex® is a registered trademark of Ansell Edmont.
Teflon® is a registered trademark of DuPont or its affiliates.